



## OperaFLO White Paper - Offshore Architecture



### Introduction

OperaFLO technology has been enhanced specifically for the offshore arena. It facilitates easy transition of business processes by employing a systems design that ensures a highly available solution coupled with a very low cost of ownership.

### Architecture Overview

The OperaFLO merge replication model offers solutions that utilise inexpensive and unreliable bandwidth, without sacrificing local application performance and availability.

All data is merge-replicated to all participating sites enabling client workstations to connect to local resources without the impact and risk commonly associated with direct connections over International WAN circuits.

One of the primary considerations when deploying offshore solutions is network connectivity. Using a reliable and high quality network is very costly, sometimes in excess of £100,000.00 per Mbit. OperaFLO removes this obstacle from the equation because it is a system that is designed to accommodate very poor quality and unreliable circuits.

There are two important considerations to this distributed approach; availability and quality:

#### *Availability*

When workstations rely on a direct connection to a remote resource, a permanently available connection is critical. This type of deployment is typical in Citrix environments. If the connection fails then access to the remote systems is not possible. Operational capabilities are only restored when the link is re-activated.

OperaFLO systems avoid this issue by replicating changes to all locations via server controlled transfer processes. The connection is initiated and maintained at the server not the workstation thus OperaFLO can cope with link downtime without degrading the service to the end user or sacrificing the operational ability of the offshore unit. Once connectivity is restored any changes made whilst being off-line will immediately synchronise with all other merge partners throughout the organisation. This process includes both database transactions and documents that have been created, scanned or modified since the last merge took place.

## Direct Connection Model

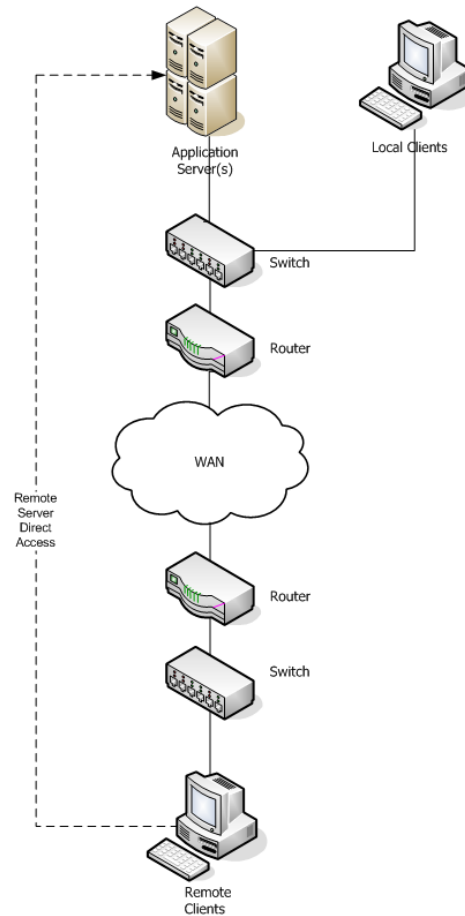

### Quality - Latency

Poor quality connections such as the Internet frequently provide periods of very high latency and packet loss.

Latency is a synonym for delay; it is the amount of time it takes for a packet to travel from source to destination. Together, latency and bandwidth define the speed and capacity of a network.

There are 3 main contributors to network latency:

**Propagation** - This is simply the time it takes for a packet to travel from one location to the other at the speed of light. The longer the distance, the greater the delay.

**Transmission** - The medium itself, usually fibre optic or copper, introduces some delay.

**Routing** - Each hop encountered between source and destination will add delay and each device will need to interrogate each packet to identify how to process it. Therefore the further a packet has to travel, the more routing devices it will encounter thus increasing the delay.

Typically the distances involved in offshore outsourcing means that substantial latency is introduced. Based on a connection to India, for every packet processed a typical overhead of

200 -300ms is introduced. This compares to a UK WAN running at < 10ms. This may not appear excessive but the combination of adding this delay to every packet processed results in very poor performance in most applications. This is particularly noticeable in applications that 'chat' a lot requiring many exchanges in communication.

The effect of high latency would be intolerable to most systems but is easily managed by an OperaFLO solution because of the nature of passive back-end replication. A user connecting directly over such a poor quality connection would find access impossible due to response times, however with OperaFLO servers are not so demanding and will still continue to replicate.

## Business Continuity

This model is ideally suited to providing a completely resilient solution. Additional servers can be added locally to provide local failover or stand-by sites prepared with identical infrastructure to aid relocation. Due to the complete replication model in use by OperaFLO any new set of replication partners automatically becomes a failover resource, regardless of location.

## Merge Replication Model

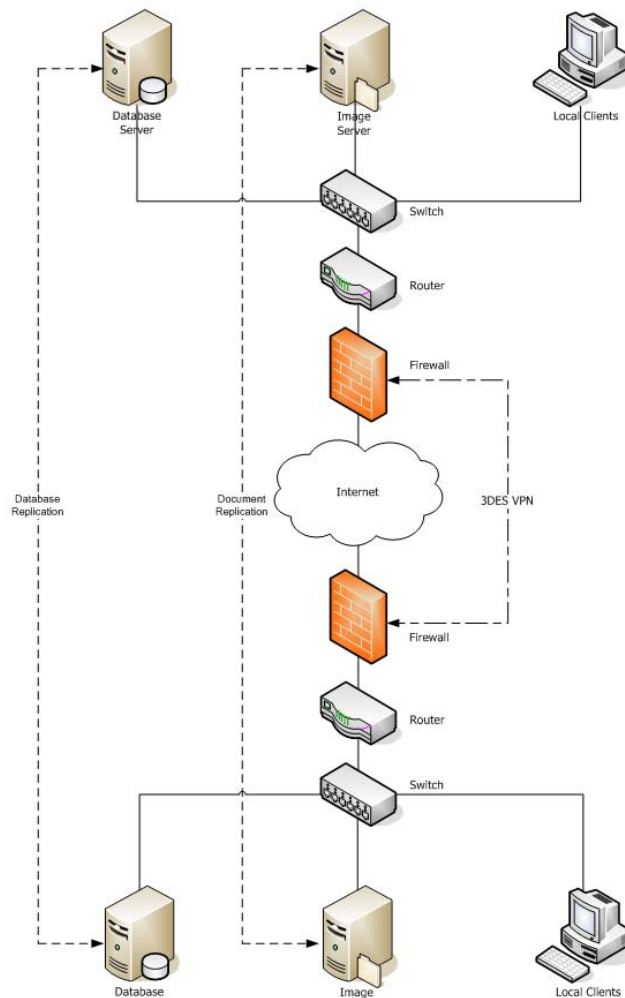

## Cluster Model

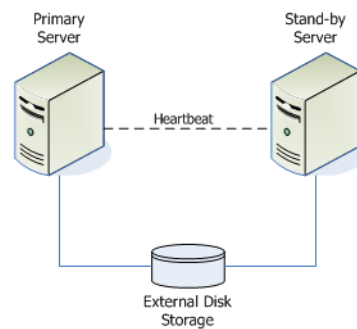

Clustering involves using two chassis and one external data storage array. The disk enclosure is connected to the host chassis via fibre allowing separation of hardware by distances measurable in miles. A heartbeat signal is sent between the active and passive partners which triggers an automatic failover event should the primary fail.

Whilst this solution provides good resilience to host failure, it does not provide contingency in the event of array failure or allow multiple active replicas of data stores. Concurrent scalability is also limited to the specification of the primary server.

OperaFLO architecture enables multiple active data-store replicas allowing massive local resilience and easily deployable scalability by simply integrating additional server arrays without disrupting existing systems or users.

## Scalability

OperaFLO's flexible design approach means that scalability is limited only by the quantity of server arrays deployed. Entry level server systems typically achieve 1000 transactions per second and are easily capable of supporting 200+ concurrent users. More complex server designs incorporating 4 or 8 way boxes with RAID-10 disk configurations can support approximately 750 users per node. This means OperaFLO installations are 'infinitely' scalable.

## Replication Partitioning & Prioritisation

The OperaFLO merge replication model provides the ability to control transfer priority and type. This is particularly important should only a subset of data need to be replicated to a specific site. Filter rules are applicable on a site by site basis so as processes and business rules change this highly adaptable model allows spontaneous replication support.

Document types can be configured with a transit priority. This enables a process based replication filter, i.e. processes that require a fast completion cycle will receive a high priority transfer. This is configurable on a site basis. All pending documents are prepared for transfer based on the configured priority class.

## Summary

OperaFLO offers a unique alternative to costly, unreliable and poorly performing on-line or thin-wire solutions. Its design provides massive benefits that will increase productivity and provide automatic resilience whilst operating over inexpensive circuits.

Failure is assumed at every level so OperaFLO provides a method of recovery that appears transparent to the end user ensuring maximum efficiency and performance from your offshore resource.

To find out more about FLOvate and any of our products and services (OperaFLO, LicenceFLO or VoiceFLO) please visit [www.flovate.com](http://www.flovate.com)

We will be happy to demonstrate any of our products to you. For either a face to face or a web based demonstration call us on **01473 405000** or email [info@flovate.com](mailto:info@flovate.com)